

OFFSET STRAIGHT LIVE TOOL HOLDER

VDI 30 / DIN 1809

Product code:
NGT1-30/321-25/1.1-50(1:2)

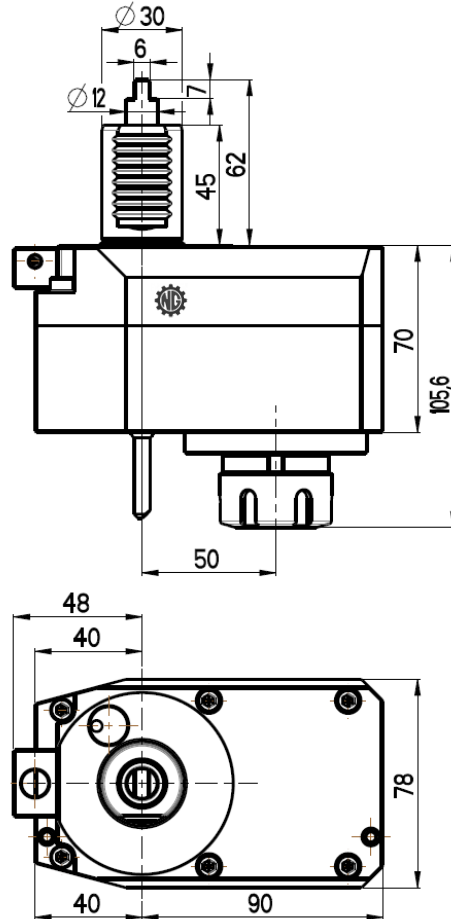

Max. speed: 12000 rpm

Max. torque: 14 Nm

Collet: ER25

Ratio: 1:2 (reverse direction)

Cooling: external (internal cooling available)

Accessories

Nut : Hook spanner type E 25

Spindle: Hook wrench DIN 1810A 40-42

