

## OFFSET STRAIGHT LIVE TOOL HOLDER

VDI 30 / DIN 5480

Product code:  
**NGT1-30/331-25/1.1-50(1:2)**

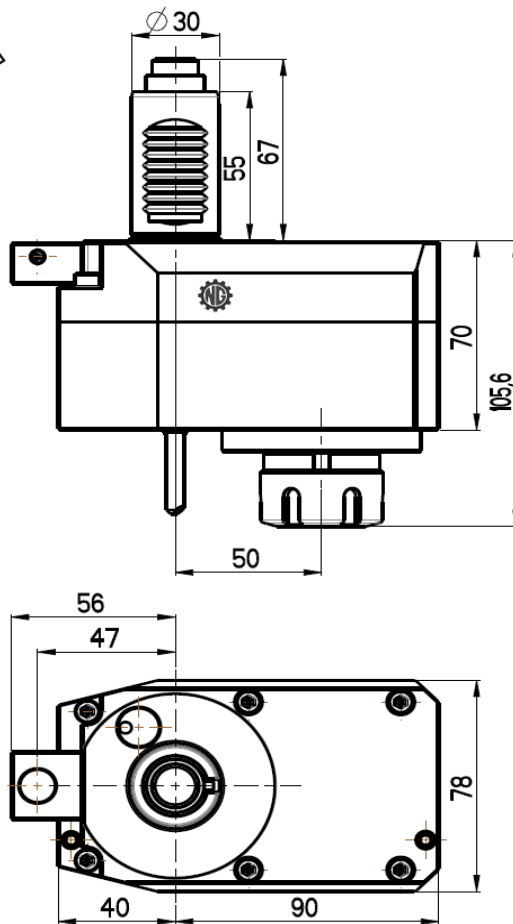

**Max. speed:** 12000 rpm

**Max. torque:** 14 Nm

**Collet:** ER25

**Ratio:** 1:2 (reverse direction)

**Cooling:** external (internal cooling available)

### Accessories

**Nut:** Hook spanner type E 25

**Spindle:** Hook wrench DIN 1810A 40-42

