

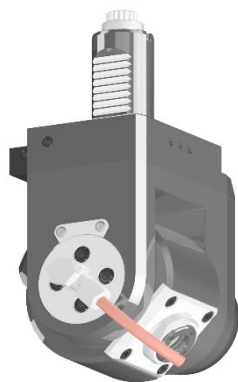

## VARIABLE ANGLE LIVE TOOL HOLDER VDI 30 / DIN 5480

Product code:  
**NGT1-30/531-16/2**

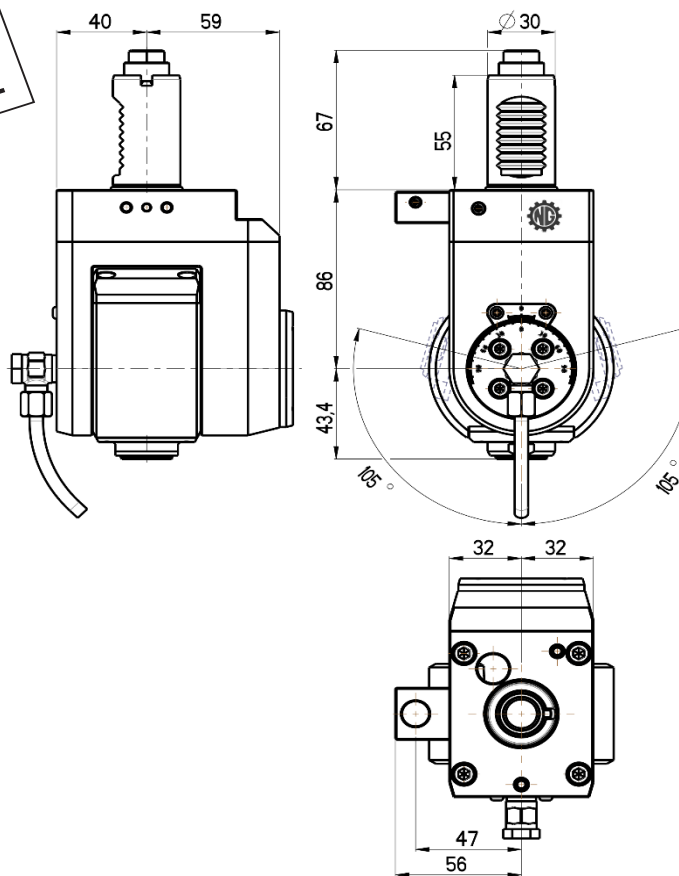

**Max. speed:** 6000 rpm

**Max. torque:** 16 Nm

**Collet:** ER16

**Ratio:** 1:1

**Cooling:** external & internal

**Max. pressure:** 20 bar

### Accessories

**Nut:** Caliper pin wrench

**Spindle:** Spanner 28

[www.microntooling.com](http://www.microntooling.com)

Subject to change without notice