

ANGULAR LIVE TOOL HOLDER

VDI 40 / DIN 1809

Product code:
NGT1-40/221-25/2.1-80

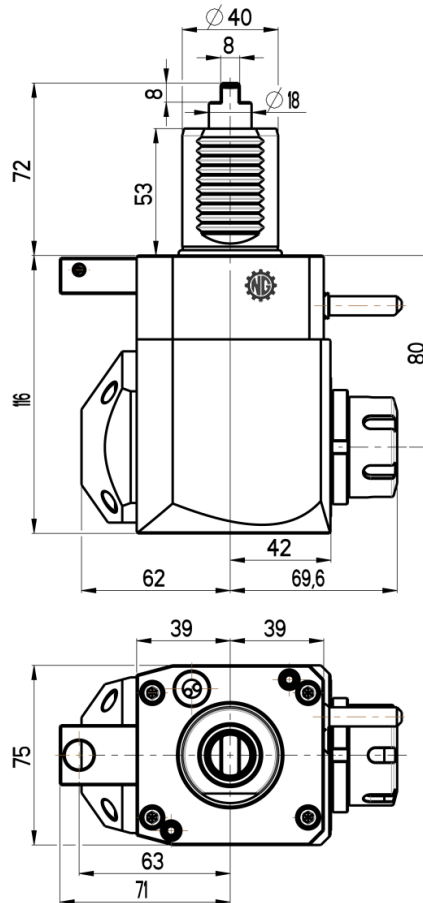
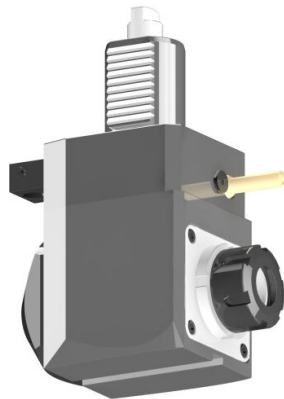

Max. speed: 6000 rpm

Max. torque: 50 Nm

Collet: ER25

Ratio: 1:1 (reverse direction)

Cooling: external & internal

Max. pressure: 20 bar

Accessories

Nut: Hook spanner type E 25

Spindle: Hook wrench DIN 1810A 45-50

