

ANGULAR LIVE TOOL HOLDER

VDI 40 / TOEM 200

Product code:

NGT1-40/241-25/1.1-80

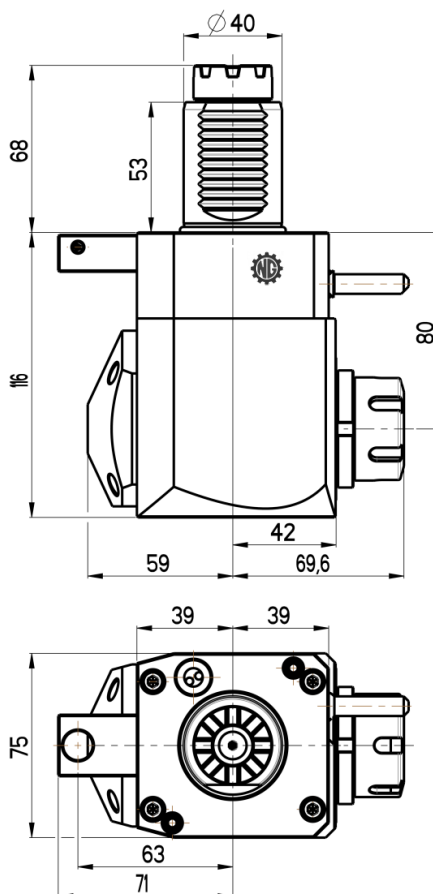
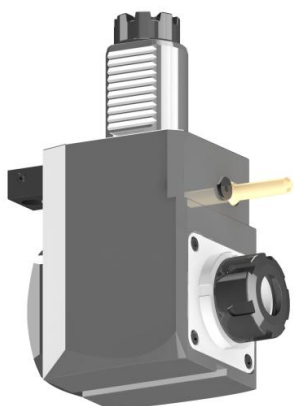

Max. speed: 6000 rpm

Max. torque: 50 Nm

Collet: ER25

Ratio: 1:1 (reverse direction)

Cooling: external (internal cooling available)

Accessories

Nut: Hook spanner type E 25

Spindle: Hook wrench DIN 1810A 45-50

