

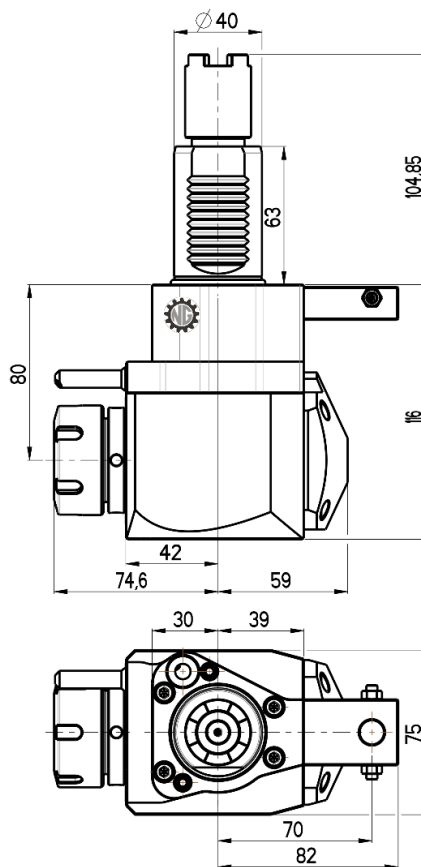

## ANGULAR LIVE TOOL HOLDER

VDI 40 / HAAS

Product code:  
**NGT1-40/251-32/1.2-80AH**



**Max. speed:** 6000 rpm

**Max. torque:** 50 Nm

**Collet:** ER32

**Direction of rotation:** 

**Ratio:** 1:1

**Cooling:** external (internal cooling available)

### Accessories

**Nut :** Clamping wrench type E 32

**Spindle:** Hook wrench DIN 1810B 45-50

